

## B-21 Plylag

**3,000 lbs. Max. Safe Working Load**

Approximate safety factor 2:1

Dayton/Richmond B-21 Plylags are used externally on modular forms to attach wales/strongbacks or internally to attach coil ties, rock anchors, etc., to the form. Plylags are manufactured from 1/2" diameter coil rod and are stocked in 6-1/4", 6-3/4", 9-3/4" and 14-3/4" lengths. Other lengths are available on special order.

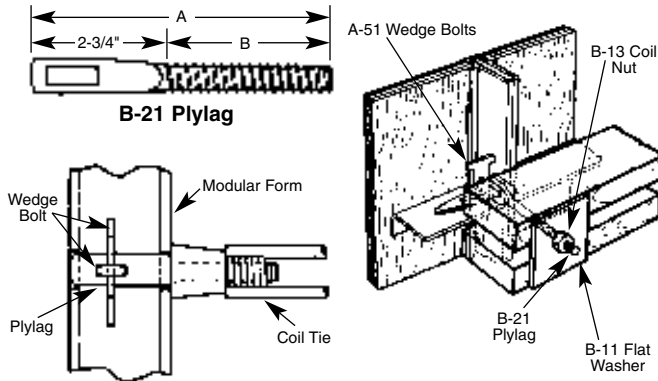

B-21 Plylag Selection Chart			
Type	Diameter	Dimensions	
		A Overall length	B Thread length
B-21	1/2"	6-1/4"	3-1/2"
B-21	1/2"	6-3/4"	4"
B-21	1/2"	9-3/4"	7"
B-21	1/2"	14-3/4"	12"

## B-1 Two Strut Coil Tie and B-2 Four Strut Coil Tie

Dayton/Richmond B-1 and B-2 Coil Ties are strong, versatile resistance welded ties designed to take the abuse encountered in medium and heavy concrete construction. The coil tie is an extremely simple tie that is capable of servicing many applications and uses in the field. It can be used with or without cones or combined with coil rod to form an adjustable tie. The coil threads are fast acting and self-cleaning.

B-2 Four Strut Coil Tie Couplers are available and are used in conjunction with D-18 Inside Rods to compensate for form variations.

To determine the required coil tie length, subtract two times the desired or specified setback from the wall thickness. [Wall thickness - (2x setback) = coil tie length].

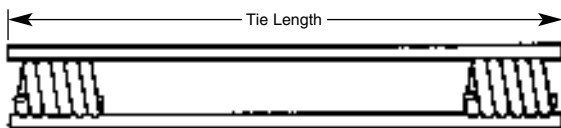

B-1 Two Strut Coil Tie

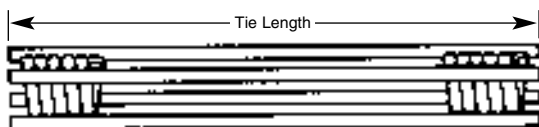

B-2 Four Strut Coil Tie and B-2 Four Strut Coil Tie Coupler

B-1 and B-2 Coil Tie Selection Chart			
Type	Bolt Diameter	Number of Strut Wires	Safe Working Load Tension (lbs.)
B-1 Standard	1/2"	2	4,500
B-1 Heavy	1/2"	2	6,750
B-1 Standard	3/4"	2	6,750
B-1 Heavy	3/4"	2	9,000
B-1 Standard	1"	2	13,500
B-2 Standard	1"	4	18,000
B-2 Standard	1-1/4"	4	27,000
B-2 Coupler 8"	1/2"	4	9,000
B-2 Coupler 12"	3/4"	4	18,000

Approximate safety factor 2:1

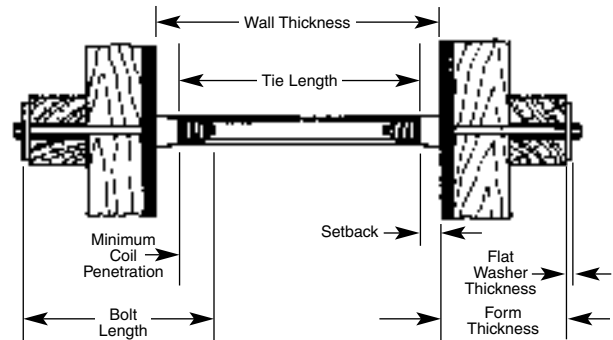

### Coil Tie with Loose (Spreader) Cones

Cones are generally used when wall thickness is very thick or an architectural finish is specified.

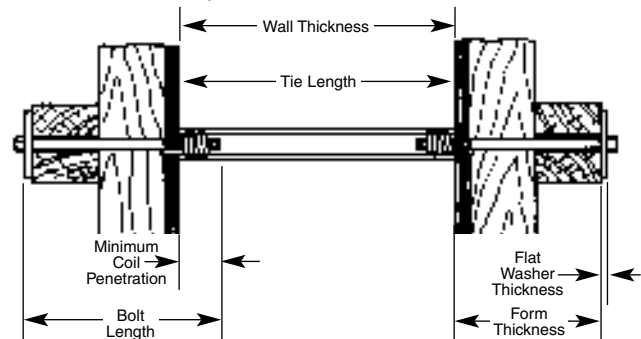

### Coil Tie as Spreader and Tie

The coil tie can be used as a combination tie and form spreader when it is not necessary to keep the ends of the tie back from the face of the concrete. If a number of form reuse is contemplated, standard cut washers should be used at the tie ends to protect the form face.

## Coils

Standard coils are available for 1/2", 3/4", 1", 1-1/4" and 1-1/2" diameter bolts.

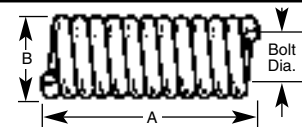

Coil Dimensions				
Bolt Diameter	A	B	Wire Diameter	Threads Per Inch
1/2"	1-1/8"	25/32"	.162"	6
3/4"	1-9/16"	1-3/32"	.218"	4-1/2
1"	2"	1-7/16"	.281"	3-1/2
1-1/4"	2"	1-11/16"	.281"	3-1/2
1-1/2"	2-5/16"	1-15/16"	.281"	3-1/2