

C-1-B and C-1-C Wedge Hangers

Dayton/Richmond C-1-B (with metal spreader washers) and C-1-C Wedge Hangers (without spreader washers) are standard or heavy snap ties that have been shaped to fit over structural steel beams to support fireproofing formwork. Wedge Hangers are normally furnished with a 1" breakback, other breakbacks are available on special order.

When using C-1-B Wedge Hangers (with spreader washers) A-16 Omni Wedges bear on drilled single or double ledgers. This secures the beam bottom against the spreader washers to provide a rigid form and correct depth of fireproofing. C-1-C Wedge Hangers (without spreader washers) are recommended for use only with soffit spacers.

Warning: Hanger must be equally loaded, on both sides of the beam, to prevent hanger rotation.

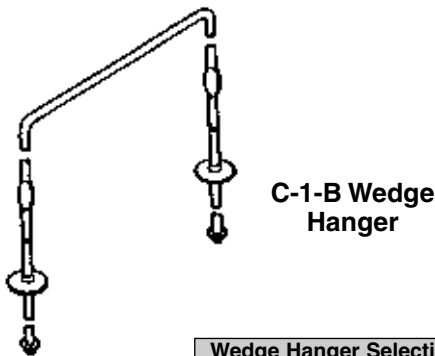
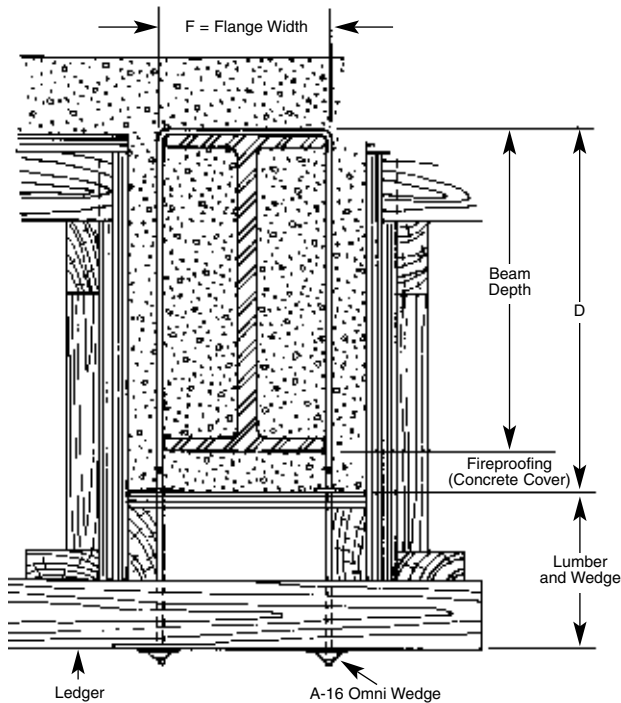

| Type | Safe Working Load |
|----------|-------------------|
| Standard | 1,500 lbs./side |
| Heavy | 2,000 lbs./side |

Approximate safety factor 2:1

C-2 Coil Hanger Saddle Type

Dayton/Richmond C-2 Coil Hanger Saddle Type consists of a two-strut coil tie shaped to fit over a structural steel beam to support fireproofing formwork.

Warning: Hanger must be equally loaded on both sides of the beam, to prevent hanger rotation.

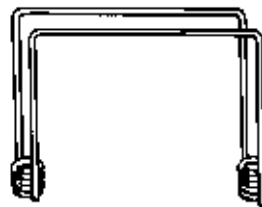
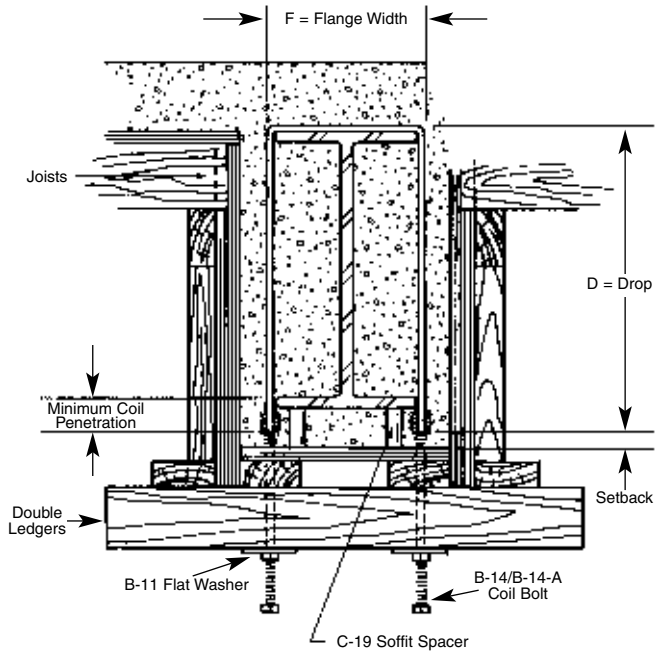

C-2 Coil Hanger

| Coil Bolt Diameter | Safe Working Load |
|--------------------|-------------------|
| 1/2" | 2,250 lbs./side |
| 3/4" | 5,625 lbs./side |
| 1" | 7,500 lbs./side |

Approximate safety factor 2:1

